



More information on the website  
[mirror.radwag.com/us/info,w1,DBD](http://mirror.radwag.com/us/info,w1,DBD)

# C315.3/6.F1.K Load Cell Platform Scale

WP-123-1002



The drawings, photos and graphics used are for illustrative purposes only.

## Functions

 Plus/Minus Control

 Percent Weighing

 Totalizing

 Parts counting

 Internal battery

 Peak hold

 Newton unit measurement

 GLP Procedures

 Animal weighing

 ALIBI Memory

## Datasheet

Maximum capacity [Max]	3 / 6 kg
Minimum load	20 g
Readability [d]	1 / 2 g
Verification unit [e]	1 / 2 g
Tare range	-6 kg
OIML Class	III

Physical parameters	
Display	4,3" LCD (backlit)
Cable length	1 m
Weighing pan dimensions	300×300 mm
Packaging dimensions W x D x H	570×390×170 mm
Net weight	5,3 kg
Gross weight	6,1 kg
Construction	
Protection class	IP 65 construction, IP 43 terminal
Construction	mild steel St3S
Weighing pan material	Stainless steel AISI304
Communication interface	RS232
Optional interfaces	RS232
Power supply	100 – 240 V AC 50/60 Hz and battery
Power consumption max.	5 W
Operation time on batteries	max 8h
Operating temperature	-10 – +40 °C
Storage temperature	-10 – +50 °C
Relative humidity	10% – 85% RH no condensation
Indicator	C315



Additional fee for verification



## Accessories (Additional Fee)

Antivibration tables  
 Power Adapters  
 RS 232 cables (scale - printer)  
 Stands, wall mounting kits and mounting brackets  
 Cigarette lighter receptacle power supply cables  
 Displays

RS 232, RS 485 cables  
 RS 232 – Ethernet Converter  
 AP2-1 Current Loop Unit  
 RS 232 – USB Converter  
 RS 232 – RS 485 Converter  
 Receipt Printer

## Software (Additional Fee)

• RAD Key [WX-010-0005]

• Scale Editor - EWAG 2.1 [WX-010-0173]

# Device dimensions W x D x H

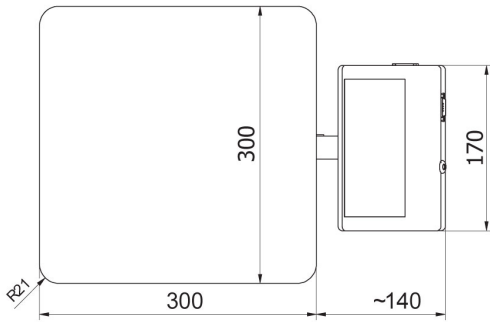
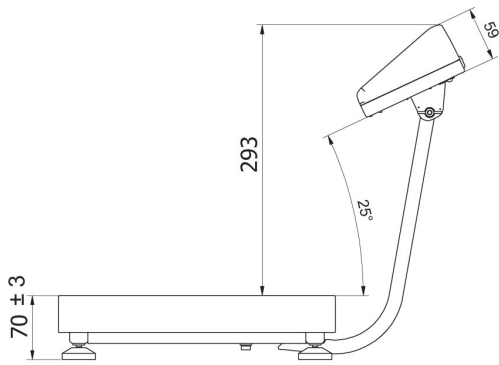

C315.F1.M

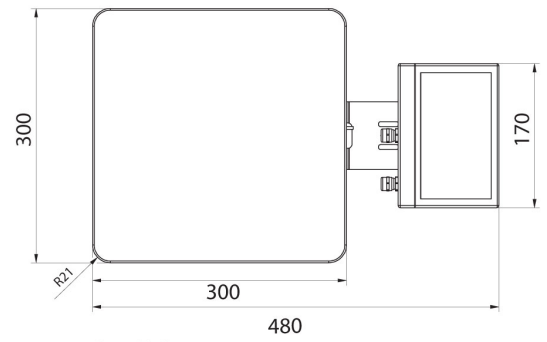
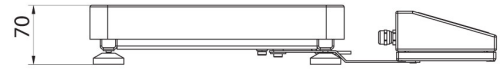

C315.F1.R

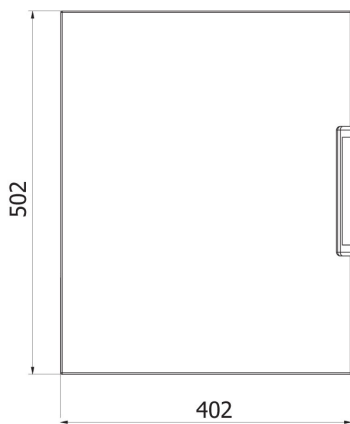
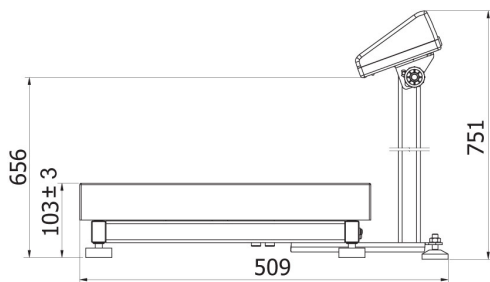

C315.C2.M

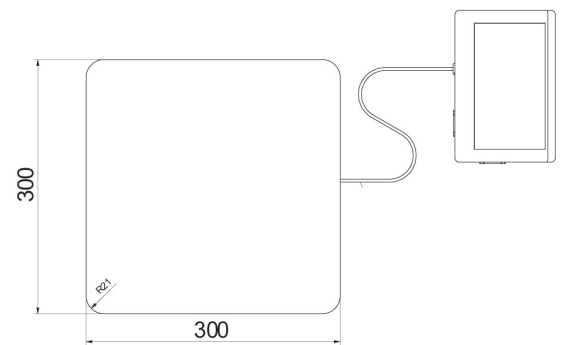
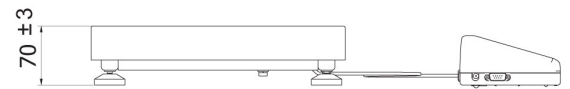

C315.C2.K