



More information on the website
mirror.radwag.com/en/info,w1,C03

PS 750.R2.H Precision Balance

WL-221-0004



The drawings, photos and graphics used are for illustrative purposes only.

Functions

-  Autotest
-  Dosing
-  Percent Weighing
-  Totalizing
-  Parts counting
-  Peak hold
-  Newton unit measurement
-  Statistics
-  Checkweighing
-  Under-pan weighing
-  GLP Procedures
-  Animal weighing
-  Density determination

Datasheet

Metrological parameters	
Maximum capacity [Max]	750 g
Minimum load	20 mg
Readability [d]	0.001 g
Tare range	-750 g
Minimum weight (USP)	1 g
Minimum weight (U=1%, k=2)	0.1 g

Metrological parameters	
Standard repeatability [5% Max]	0.0005 g
Repeatability (Max)	0.0015 g
Linearity	±0.003 g
Stabilization time	2 s
Adjustment	internal (automatic)
Sensitivity temperature drift	$2 \times 10^{-6} / ^\circ\text{C} \times \text{Rt}$
Physical parameters	
Leveling system	manual
Display	5.3" LCD (backlit)
Weighing pan dimensions	ø100 mm
Packaging dimensions W x D x H	475x380x345 mm
Net weight	3.5 kg
Gross weight	5.5 kg
Construction	
Protection class	IP 54
Communication interface	
Communication interface	2xRS232 ¹ , USB-A, USB-B, Wi-Fi (option)
Electrical parameters	
Power supply	Adapter: 100 – 240V AC 50/60Hz 0.6A Max; 12V DC 1.2A Balance: 12 – 15V DC 0.7A max; 3 – 5.5W*
Power consumption	4 W
Environmental conditions	
Operating temperature	+10 – +40 °C
Relative humidity	40% – 80%

Repeatability is expressed as a standard deviation from 10 weighing cycles.

Stabilization time depends on the ambient conditions and the dynamics of weighing pan loading; specified for FAST profile.

¹ Barcode scanners, available as weighing instrument accessory, communicate with the instrument via RS232 interface exclusively.

* Wi-Fi® is a registered trademark of Wi-Fi® Alliance.



Accessories (Additional Fee)

Antivibration Tables
Power Adapters
Cigarette lighter receptacle power supply cables
USB cable (scale - printer)
Barcode scanners
RS 232, RS 485 cables

Displays
Receipt Printer
Protective cover for balances
Under-pan weighing
RS 232 cables (scale - printer)

Software (Additional Fee)

• RAD Key [WX-010-0005]
• Alibi Reader [WX-010-0114]

• R-Panel [WX-010-0187]
• R-Lab [WX-010-0080]

Device dimensions W x D x H

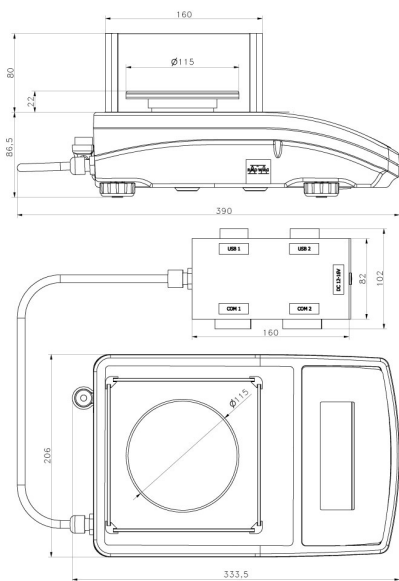

PS R2.H, d = 1 mg

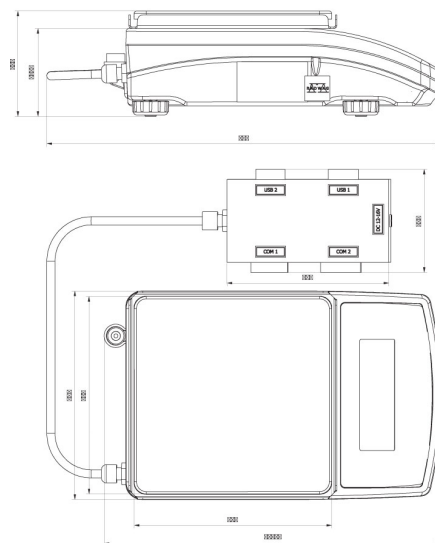

PS R2.M.H, d = 10 mg