



More information on the website  
[mirror.radwag.com/fr/info,w1,BK3](https://mirror.radwag.com/fr/info,w1,BK3)

# Ioniseur antistatique DJ-05



The drawings, photos and graphics used are for illustrative purposes only.

## Paramètres Techniques

Paramètres électriques	
Alimentation	100 – 240 V AC 50/60 Hz
Conditions environnementales	
Température du travail	0 – +40 °C
Humidité relative d'air	5% – 80%
Distance d'échantillon	Ok. 5 – 50 mm
Source d'ions	acier inoxydable
Paramètres physiques	
Dimensions de châssis	175×70×172 mm
Dimensions de colis	375×375×130 mm
Masse nette	1,3 kg
Masse brute	2,5 kg

## Compatible avec

## Dimensions d'appareil

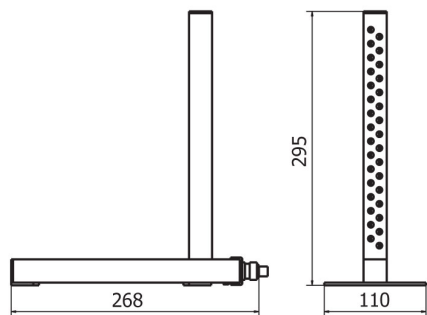

DJ-04

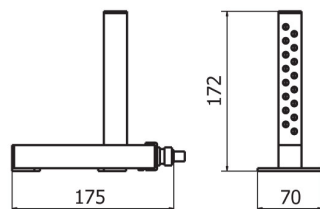

DJ-05

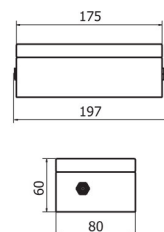

power supply