



More information on the website  
[mirror.radwag.com/fr/info,w1,BJ8](https://mirror.radwag.com/fr/info,w1,BJ8)

# Rampe pour la balance C11 3000kg



The drawings, photos and graphics used are for illustrative purposes only.

## Paramètres Techniques

Paramètres métrologiques	
Précision de lecture maximale pour les balances non vérifiées	200 g
Construction	
Matière	acier pulvériséacier
Paramètres physiques	
Dimensions de rampe	2000×1995 mm



## Compatible avec

Balance multifonctionnelle à plateforme HX7.4C  
 Balance étanche de rampe C315.4

Balance à plateformes H315 4C

# Dimensions d'appareil

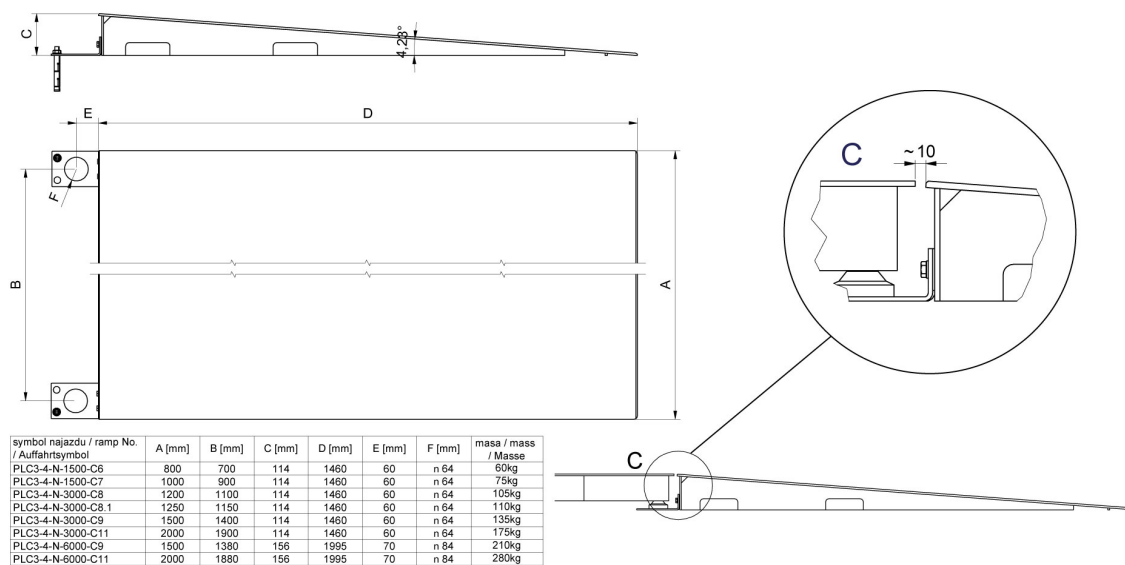

## Ramps made of powder-coated steel

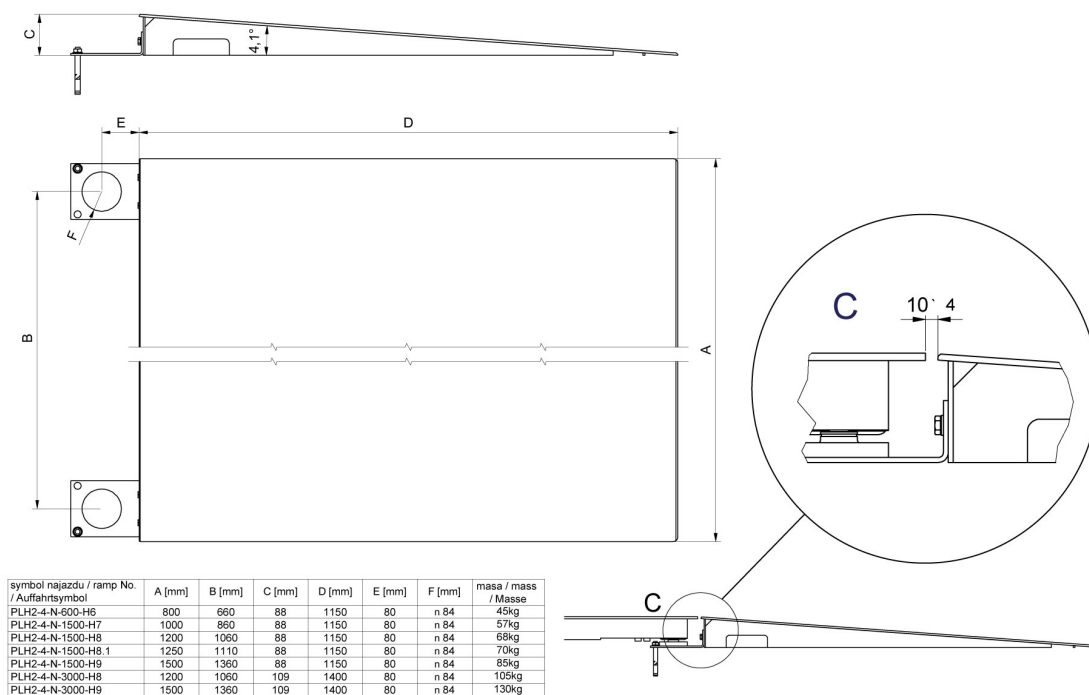

## Ramps made of stainless steel