



More information on the website
mirror.radwag.com/de/info,w1,BJ8

Rampe für C11 3000kg Wägebrücken



The drawings, photos and graphics used are for illustrative purposes only.

Technische Daten

Messtechnische Parameter	
Max Ablesbarkeit [d] bei nicht geeichter Waage	200 g
Konstruktion	
Material	pulverbeschichteter Stahl
Physikalische Parameter	
Abmessungen Wägebrücke	2000×1995 mm



Kompatibel mit

Multifunktions- Plattformwaage HX7.4C
 Plattformwaagen C315.4

Plattformwaage
 H315 4C

Abmessungen des Geräts

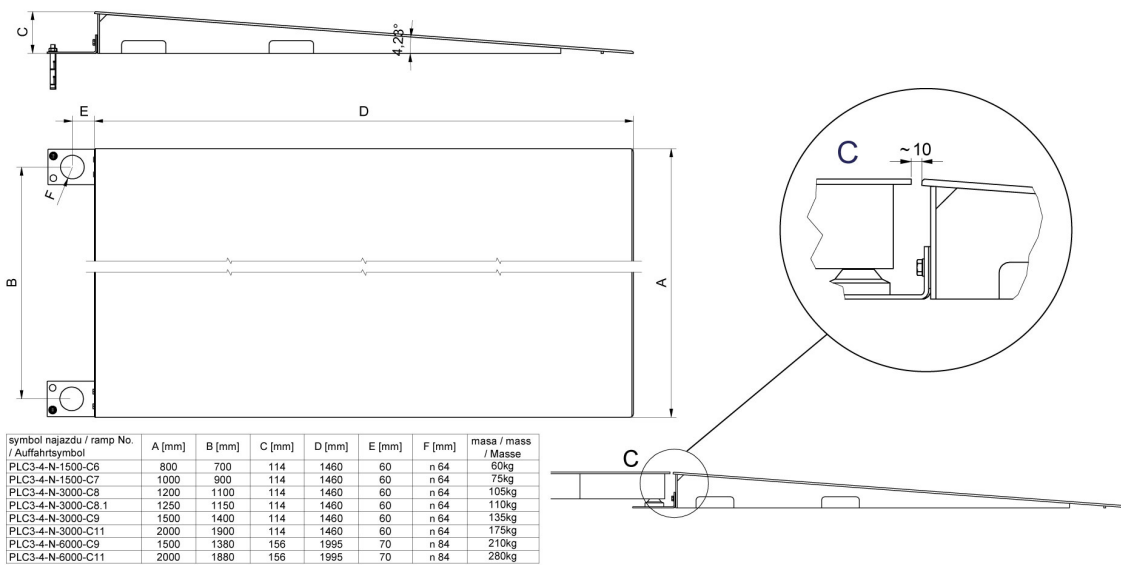

Ramps made of powder-coated steel

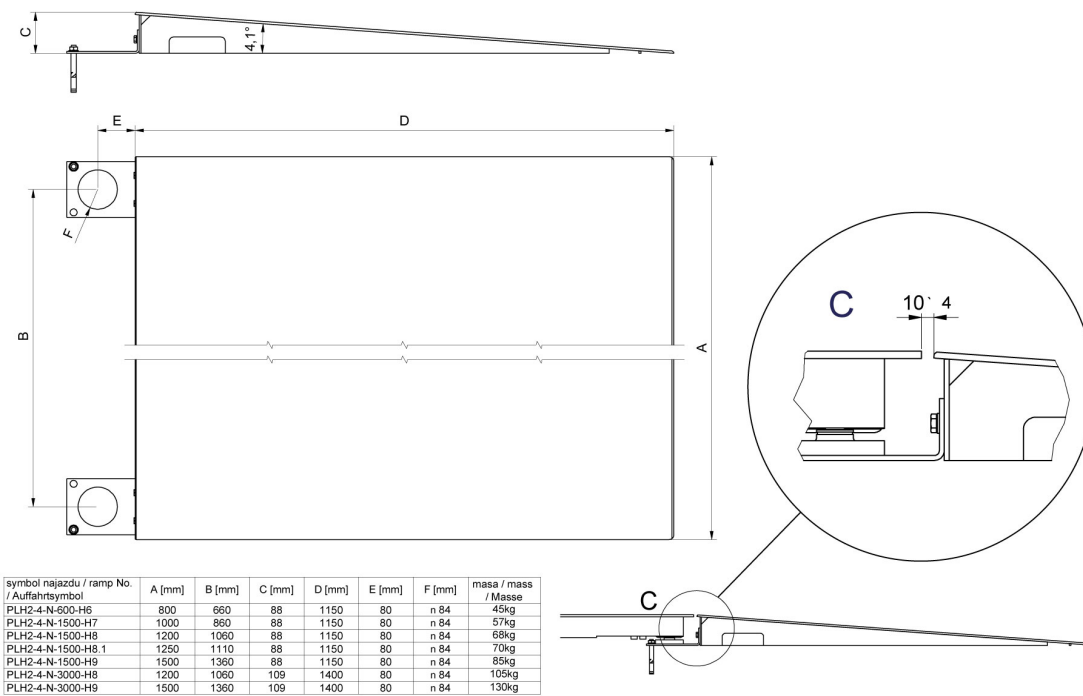

Ramps made of stainless steel