



More information on the website
mirror.radwag.com/ja/info,w1,B97

KIT 128 密度測定キット

WX-002-0001



The drawings, photos and graphics used are for illustrative purposes only.

概要

KIT 128 は、128x128 の計量皿を備えた分析用はかり向けの密度測定キットです。

このステンレス製アクセサリーを使用すると、以下の物質の密度を測定できます：

固体（粒状物を含む）液体

密度が 1 g/cm^3 より高いまたは低い粒状物の測定には、KIT 85 を使用してください。

互換性あり (Additional Fee)

PGC用PS 3Y天秤
PS X7 上皿天秤
PS 5Y 上皿天秤
PS X2 上皿天秤

PS R1 上皿天秤
PGC用PS X7天秤
PS R2 上皿天秤
PGC用PS X2天秤

デバイスの寸法

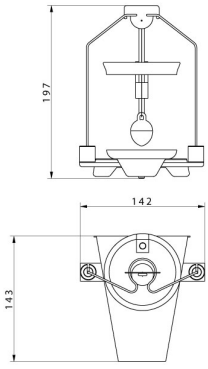

KIT 85



KIT 128

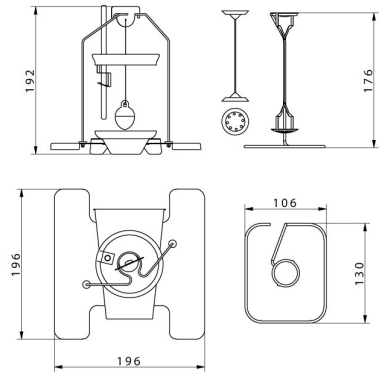

KIT 195

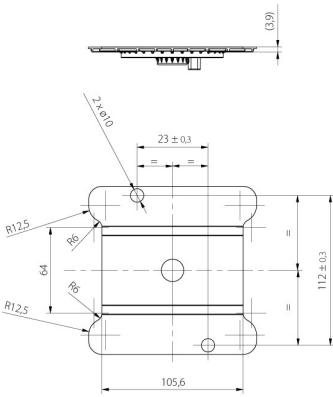

KIT 195.M

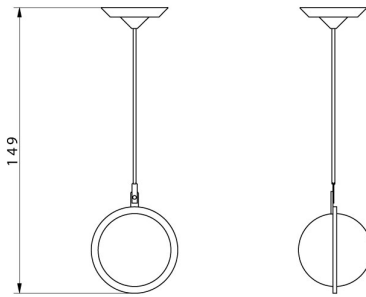

Granulte density
determination KIT