



More information on the website
mirror.radwag.com/en/info,w1,B5C

PSW Professional Single Weighing Workstation

WX-001-0020



The drawings, photos and graphics used are for illustrative purposes only.

Datasheet

Physical parameters	
Delivery components	table for calibration, anti-vibration table
Packaging dimensions W x D x H	1160×820×986 mm
Net weight	150 kg (table 110 + stone 40)
Gross weight	171 kg
Length	1100 mm
Width	750 mm
Height	1100 mm
Number of workstations	1



Compatible with (Additional Fee)

XA 5Y.M.A.P Microbalance for pipettes calibration
 MYA 5Y.P Microbalance for pipettes calibration

CY10 Precision Balance
 XA 5Y.F Analytical Balance for Filters

5Y.PM Precision Balance
 MYA 5Y.F Microbalance for Filters
 AS X7 Analytical Balance
 XA 5Y.M.A Microbalance
 C32.PM Precision Balance
 XA 5Y.A Analytical Balance
 UYA 5Y Ultra-Microbalance
 AS 5Y Analytical Balance
 PS 5Y Precision Balance
 PS 5Y Balances for PGC

MYA 5Y Microbalance
 XA 5Y Analytical Balance
 AS R2 PLUS Analytical Balance
 XA 5Y.M Microbalance
 UYA 5Y.KO Manual Mass Comparator
 AS R1 PLUS Analytical Balance
 UYA 5Y.F Ultra-Microbalance for Filters
 XA 5Y.M.A.S Microbalance for stents weighing
 MAS.1.Y Modules

Device dimensions W x D x H

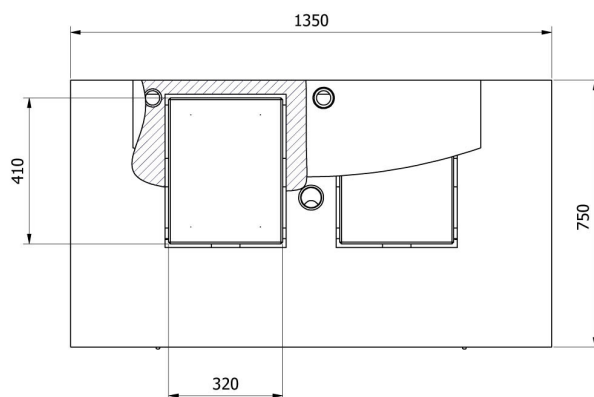
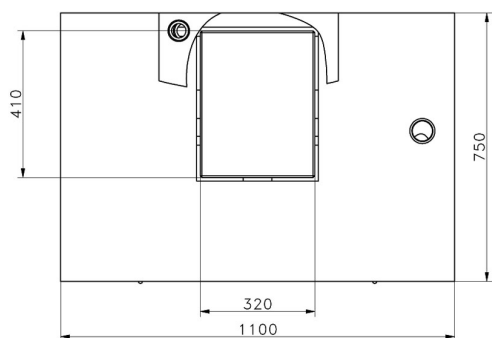
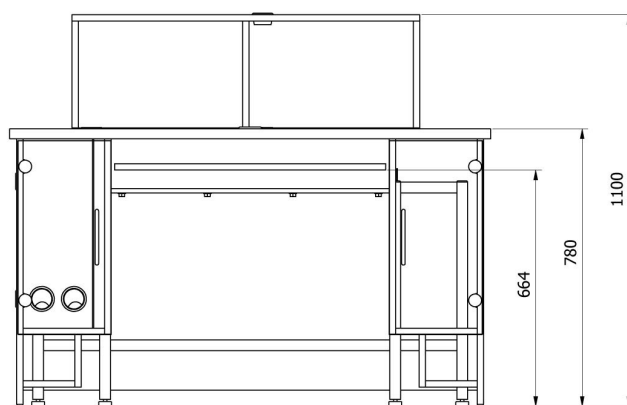
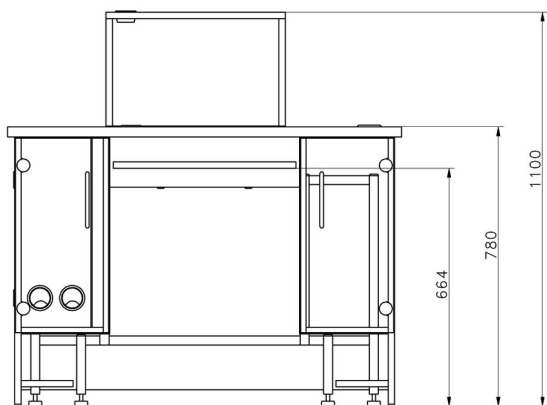

—SDKP

—SDKP DUAL