



More information on the website
mirror.radwag.com/tr/info,w1,AOG

MAS.1.21.R Tartım Modülü

WX-016-0147



The drawings, photos and graphics used are for illustrative purposes only.

Teknik Veriler

Metrolojik parametreler	
Maksimum yük [Max]	21 g
Minimum yük [Min]	1 mg
Ön yük	2,1 g
Okuma içiğruluđu [d]	0,01 mg
Dara aralıđı	-21 g
Minimum ađırlık (USP)	24 mg
Minimum ađırlık (U=1%,k=2)	2,4 mg
Tekrarlanabilirlik (Max)	0,025 mg
Düşük yükte tekrarlanabilirlik	0,012 mg
Dođrusallık	±0,06 mg
Kararlılık süresi	6 s
Fiziksel parametreler	
Display	LCD (aydınlatma ile)
Tartım kefesi boyutları	ø33 mm
Cihaz boyutları	289×143×125 mm

Fiziksel parametreler	
Ambalaj boyutları	650×340×315 mm
Net ağırlık	4,7 kg
Brüt ağırlık	6 kg
Konstrüksiyon	
IP Sınıfı	IP 54
Haberleşme arayüzler	
Haberleşme arayüzü	RS232
Elektrik parametreleri	
Güç kaynağı	100 – 240 V AC 50/60 Hz
Çevresel koşullar	
Çalıştırma sıcaklığı	+10 – +40 °C
Atmosferik nem	40% – 80%



Aksesuarlar (Additional Fee)

RS 232 cables (scale - printer)
Antivibrasyon masaları
RS 232, RS 485 cables

Profesyonel tartım masaları
RS 232 – USB Converter
RS 232, RS 485 Kabloları

Yazılım (Additional Fee)

• RAD Key [WX-010-0005]
• R-Lab [WX-010-0080]

• R Panel [WX-010-0187]
• RADWAG Development Studio [WX-010-0104]

Cihaz boyutları

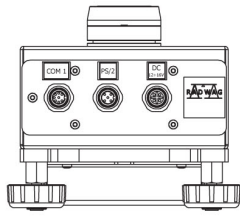

MAS.1
MAS.1.R



MAS.1

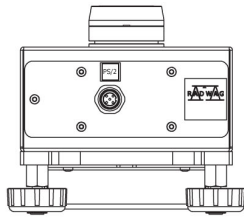

MAS.1.Y



MAS

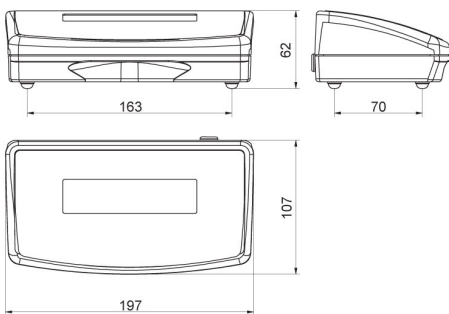

R operator panel



Y operator panel