



More information on the website
mirror.radwag.com/pl/info,w1,9VJ

Szafka przeciwpodmuchowa do mikrowag



Użyte rysunki, zdjęcia, grafiki mają charakter poglądowy.

Dane techniczne

Parametry fizyczne	
Wymiar	560x350x252 mm
Wymiary opakowania	695x485x385 mm
Masa netto	7,6 kg
Masa brutto	10,9 kg

Pasuje do

Moduły MUYA

Mikrowaga do kalibracji pipet XA 5Y.M.A.P

Mikrowaga do kalibracji pipet MYA 5Y.P

Mikrowaga do filtrów MYA 5Y.F

Mikrowaga XA 5Y.M.A

Mikrowaga MYA 5Y

Mikrowaga XA 5Y.M

Mikrowaga do ważenia stentów XA 5Y.M.A.S

Wymiary urządzenia

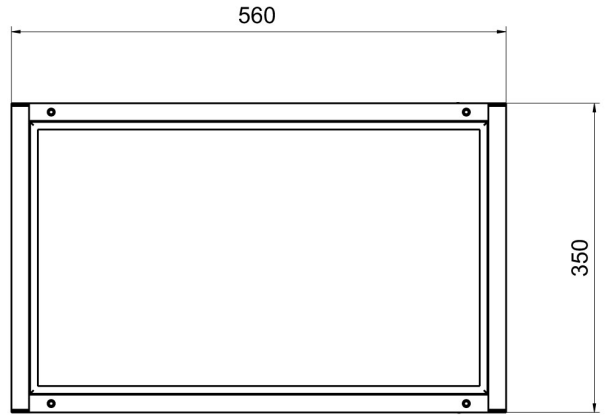
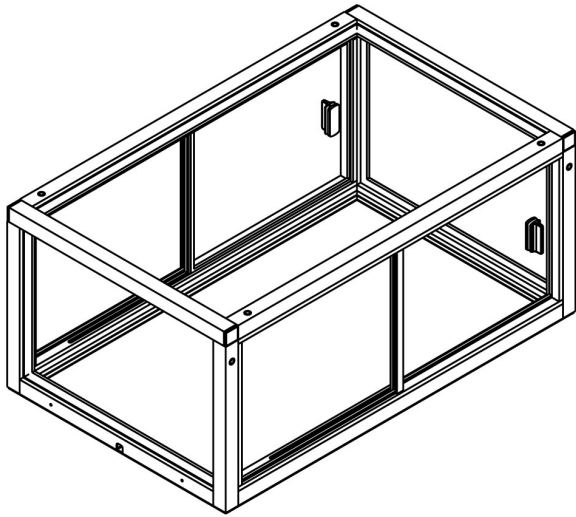
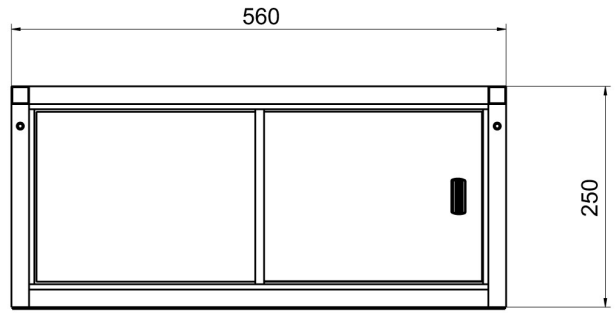
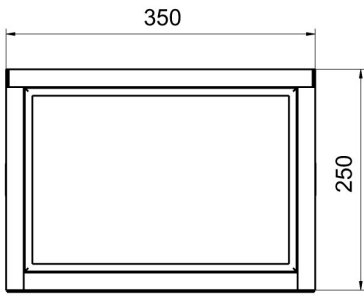



Anti-draft chamber for balances with 128x128 mm weighing pan

Anti-draft chamber for X2 and R2 precision balances



Anti-draft chamber for microbalances

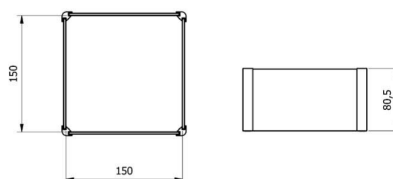

Draft shield for precision balances

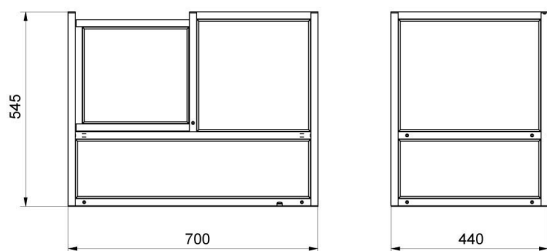

Anti-draft chamber for APP-00-SK mass comparators

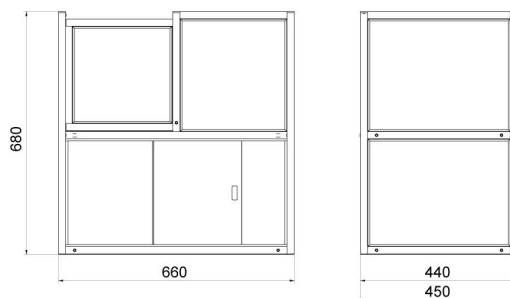

Anti-draft chamber for APP-KO-SK mass comparators

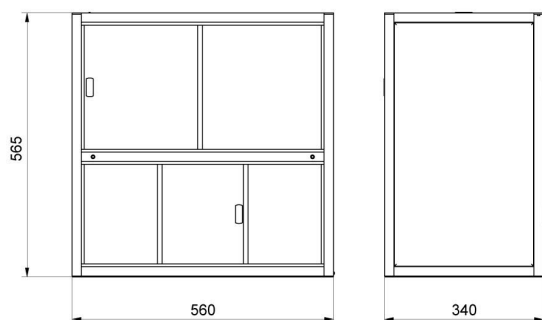

Anti-draft chamber for WAY-KO mass comparators

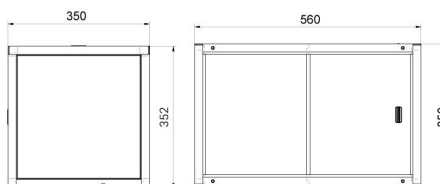

Anti-draft chamber for XA 5Y / XA 5Y.A balances