



More information on the website
mirror.radwag.com/fr/info,w1,9VJ

Boîte anti-courant d'air pour microbalances



The drawings, photos and graphics used are for illustrative purposes only.

Paramètres Techniques

Paramètres physiques	
Dimension	560x350x252 mm
Dimensions de colis	695x485x385 mm
Masse nette	7,6 kg
Masse brute	10,9 kg

Compatible avec

Modules MUYA
 Microbalance pour étalonnage des pipettes XA 5Y.M.A.P
 Microbalance pour étalonnage des pipettes MYA 5Y.P
 Microbalance pour filtres MYA 5Y.F

Microbalance XA 5Y.M.A
 Microbalance MYA 5Y
 Microbalance XA 5Y.M
 Microbalance pour stents XA 5Y.M.A.S

Dimensions d'appareil

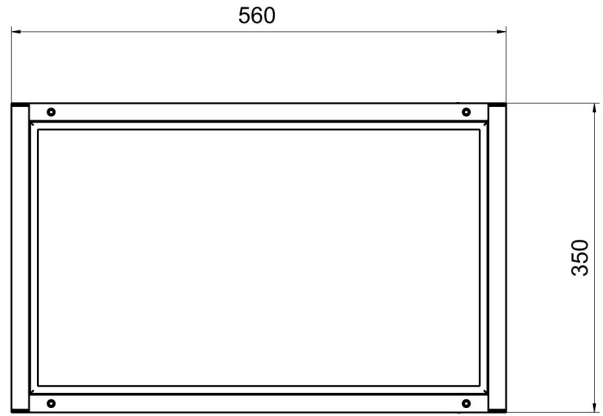
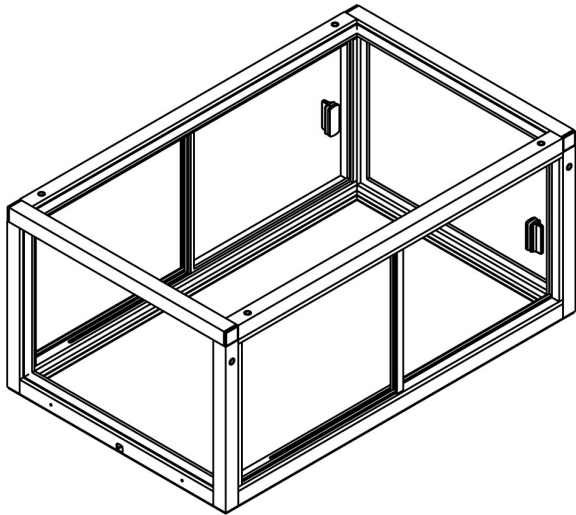
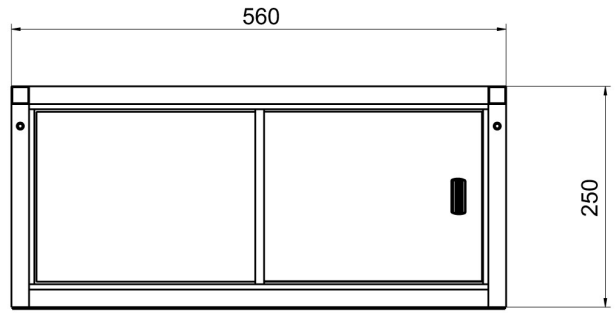
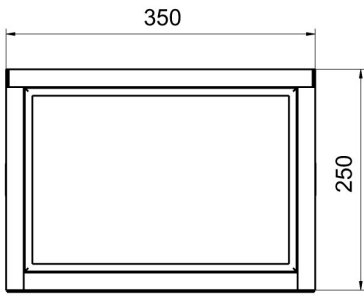



Anti-draft chamber for balances with 128x128 mm weighing pan

Anti-draft chamber for X2 and R2 precision balances



Anti-draft chamber for microbalances

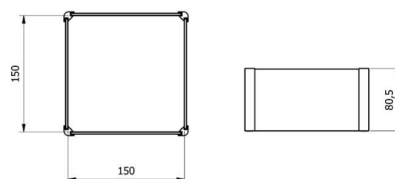

Draft shield for precision balances

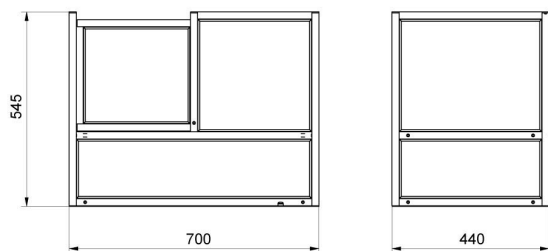

Anti-draft chamber for APP-00-SK mass comparators



Anti-draft chamber for APP-KO-SK mass comparators



Anti-draft chamber for WAY-KO mass comparators



Anti-draft chamber for XA 5Y / XA 5Y.A balances