



More information on the website
mirror.radwag.com/it/info,w1,8F2

KIT 85 Kit per la determinazione della densità

WX-001-0001



The drawings, photos and graphics used are for illustrative purposes only.

Caratteristiche generali

Kit per la determinazione della densità per solidi e liquidi progettato per essere utilizzato con bilance da laboratorio con piatto di pesata di 85 e 100mm.

Il kit per la determinazione della densità è utilizzabile per la determinazione di:

solidi; liquidi.

Compatibile con (Additional Fee)

AS X7 Bilancia analitica
 Bilancia analitica XA 5Y.A
 Bilancia analitica AS 5Y
 Bilancia analitica per filtri XA 5Y.F

Bilancia analitica XA 5Y
 Bilancia analitica AS R2 PLUS
 Bilancia analitica AS R1 PLUS

Device dimensions L x P x A



KIT 85

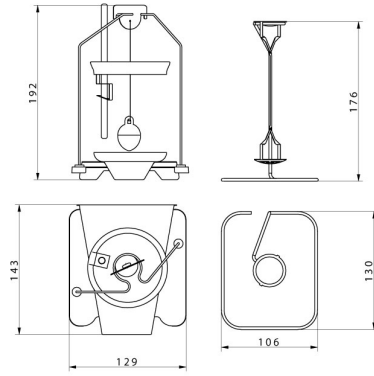

KIT 128

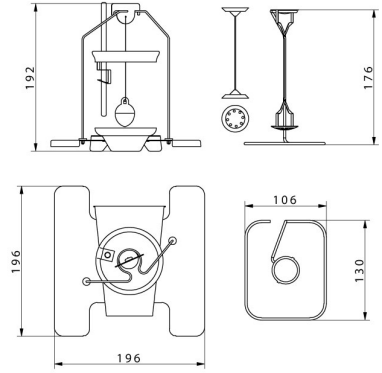

KIT 195



KIT 195.M



Granulte density determination KIT