



More information on the website  
[mirror.radwag.com/en/info,w1,8CF](http://mirror.radwag.com/en/info,w1,8CF)

# MPS 2000.R Weighing Module

WX-016-0237



The drawings, photos and graphics used are for illustrative purposes only.

## Datasheet

Metrological parameters	
Maximum capacity [Max]	2000 g
Minimum load	20 mg
Preload range	200 g
Readability [d]	1 mg
Tare range	-2000 g
Repeatability	0.5 mg
Linearity	±4 mg
Stabilization time	3 s
Adjustment	internal (automatic)
Physical parameters	
Display	LCD (backlit)
Weighing pan dimensions	ø115 mm
Device dimensions	293×190×112 mm
Packaging dimensions	610×340×285 mm
Net weight	4.7 kg

Construction	
Protection class	IP 32
Housing	aluminum
Communication interface	
Communication interface	RS232, USB-B
Electrical parameters	
Power supply	100 – 240 V AC 50/60 Hz
Environmental conditions	
Operating temperature	+10 – +40 °C
Relative humidity	40% – 80%



## Accessories (Additional Fee)

Antivibration Tables  
Professional Weighing Tables  
RS 232, RS 485 cables

RS 232 – USB Converter  
RS 232 cables (scale - printer)

## Software (Additional Fee)

- RAD Key [WX-010-0005]
- R-Lab [WX-010-0080]

- R-Panel [WX-010-0187]
- RADWAG Development Studio [WX-010-0104]

## Device dimensions

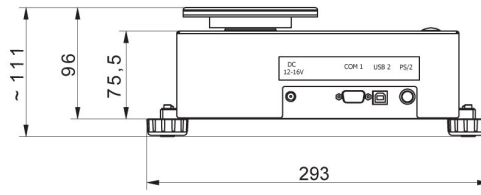
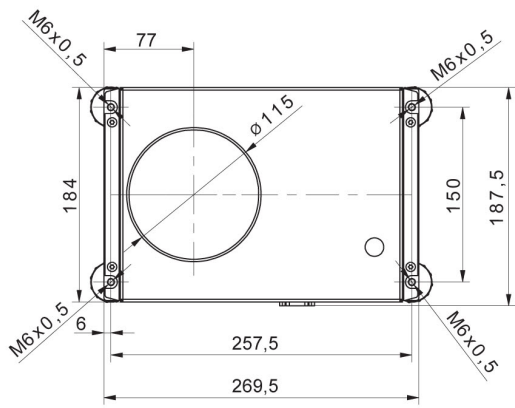

### MPS



### R operator panel



### Y operator panel