



More information on the website  
[mirror.radwag.com/us/info,w1,821](http://mirror.radwag.com/us/info,w1,821)

# AGV-8 1000.5Y Automatic Comparator for determination of mass standard's density and volume

WL-418-0004



The drawings, photos and graphics used are for illustrative purposes only.

## Datasheet

Metrological parameters	
E0 Calibration Range	1 g – 1 kg *
E1 Calibration Range	1 g – 1 kg
Maximum capacity [Max]	1110 g
Readability [d]	0,01 mg
Standard repeatability [Max]	0,05 mg
Standard repeatability [5% Max]	0,04 mg
Permissible repeatability	0,08 mg
Linearity	±0,12 mg
Electric compensation range	-10 g – +110 g
Stabilization time	30 s
Adjustment	external
Physical parameters	
Display	10" graphic colour touchscreen

Physical parameters	
Weighing pan dimensions	ø60 mm
Object diameters	5 – 94 mm
Weighing device dimensions	690×710×1060 mm
Construction	
Supplementary weights external	500 g, 300 g, 100 g, 100 g
Magazine	8
Electrical parameters	
Power supply	100 – 240 V AC 50/60 Hz
Environmental conditions	
Operating temperature	+15 – +30 °C
Storage temperature	-20 – +50 °C
Operating temperature change rate	±0,5 °C / 12 h (±0,3 °C / 4 h)
Relative humidity	40% – 60%
Relative humidity change rate	±5% / 12 h (3% / 4 h)



## Accessories (Additional Fee)

RFID Tags  
 Antivibration tables  
 Additional modules  
 Protective cover for balances  
 Barcode scanners

RS 232, RS 485 cables  
 THBR 2.0 System - Ambient Conditions Monitoring  
 Receipt Printer  
 Fingerprint Reader  
 RS 232 cables (scale - printer)

## Software (Additional Fee)

• RMCS System Network Management of Calibration Process [WX-010-0048]

## Device dimensions W x D x H



AGV-8/1000

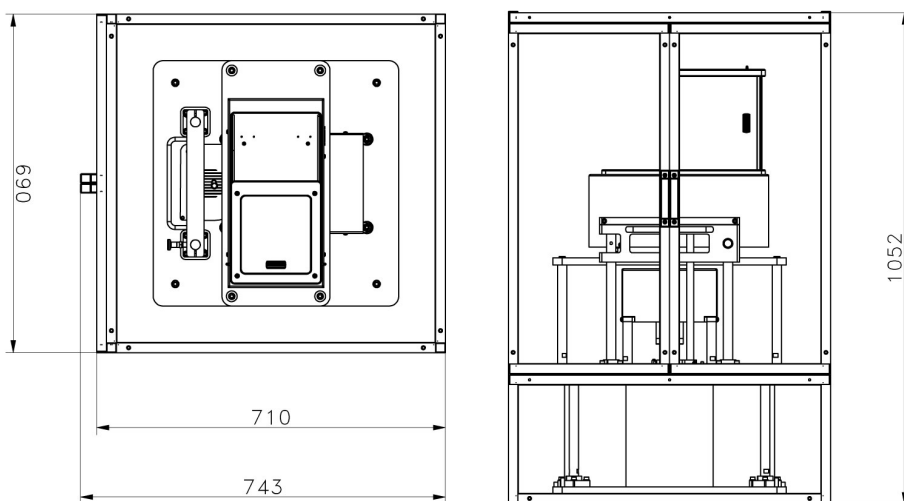

AGV-8/1000  
Anti-draft chamber ver.1

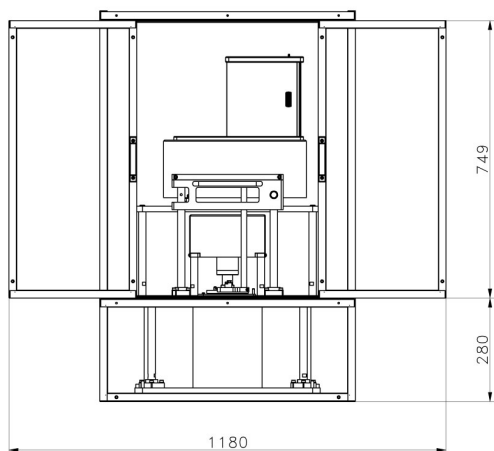

AGV-8/1000  
Anti-draft chamber ver.2