



More information on the website
mirror.radwag.com/us/info,w1,7KQ

H315.4.150.H6/Z Stainless Steel Platform Scale, pit version

WP-233-0001



The drawings, photos and graphics used are for illustrative purposes only.

Functions

 Plus/Minus Control

 Percent Weighing

 Totalizing

 Parts counting

 Internal battery

 Peak hold

 Newton unit measurement

 Animal weighing

Datasheet

Maximum capacity [Max]	150 kg
Minimum load	1 kg
Readability [d]	50 g
Tare range	-150 kg
Max readability for non-verified scale	20 g
OIML Class	III
Physical parameters	
Display	4,3" LCD (backlit)
Cable length	3 m

Physical parameters	
Weighing pan dimensions	800×800 mm
Weighing platform height	88 mm
Packaging dimensions W x D x H	1000×1000×530 mm
Scale mass with indicator and frame	75 kg
Construction	
Protection class	IP 66 / 69 construction, IP 66 / 67 / 69 terminal
Communication interface	RS232, USB
Optional interfaces	RS232 or RS485 or 4IN/4OUT or Ethernet or analog output 4-20 mA
Power supply	100 – 240 V AC 50/60 Hz
Optional power supply	internal rechargeable battery
Operation time on batteries	max 7h
Operating temperature	-10 – +40 °C
Relative humidity	10% – 85% RH no condensation



Additional fee for verification



Accessories (Additional Fee)

RS 232 cables (scale - printer)
 Displays
 RS 232 cables (scale - Ethernet)
 RS 232, RS 485 cables
 Power Adapters
 RS 232 – Ethernet Converter

USB adapter
 Receipt Printer
 USB cable (scale - printer)
 Stands, wall mounting kits and mounting brackets
 RS 232 – USB Converter

Software (Additional Fee)

• RAD Key [WX-010-0005]

• Scale Editor - EWAG 2.1 [WX-010-0173]

Device dimensions W x D x H

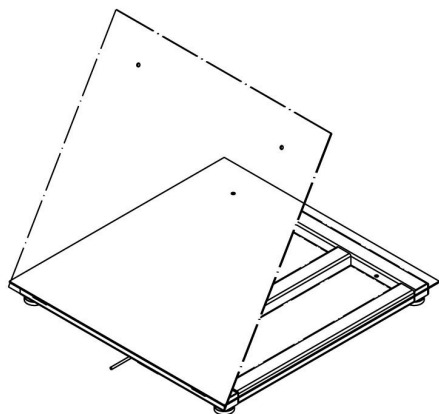

Single-leaf platform:
 H315.4.H6/Z
 H315.4.H7/Z
 H315.4.H8/Z

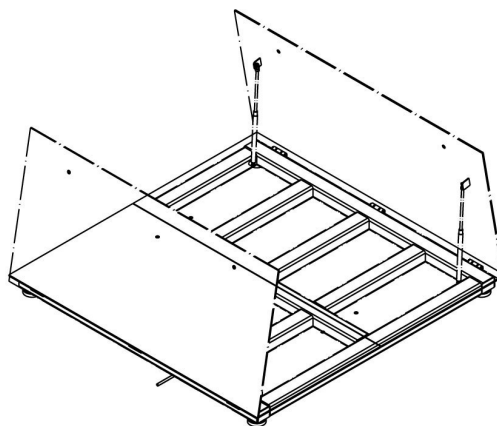

Double-leaf platform:
 H315.4.H8/9/Z
 H315.4.H9/Z
 H315.4.H10/Z

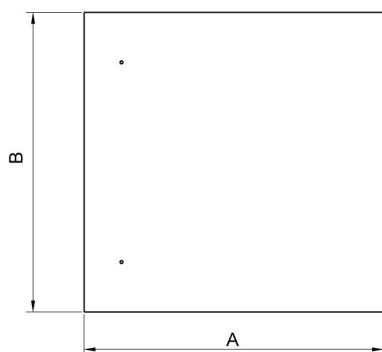
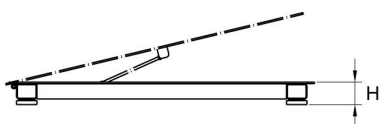

Scale type	A	B	H
H315.4.150-600.H6/Z	800	800	88±2
H315.4.150-1500.H7/Z	1000	1000	88±2
H315.4.300-1500.H8/Z	1200	1200	88 ±2
H315.4.3000.H8/Z	1200	1200	111 ±2
H315.4.300-1500.H8/9/Z	1200	1500	88 ±2
H315.4.3000.H8/9/Z	1200	1500	111 ±2
H315.4.300-1500.H9/Z	1500	1500	88 ±2
H315.4.3000-6000.H9/Z	1500	1500	111 ±2
H315.4.600-6000.H10/Z	1500	2000	111 ±2

dimensions in mm