



More information on the website
mirror.radwag.com/en/info,w1,303

WAY 2.5Y.KO Mass Comparator



The drawings, photos and graphics used are for illustrative purposes only.

Datasheet

Metrological parameters	
E1 Calibration Range	1 – 2 kg
E2 Calibration Range	500 g – 2 kg
F1 Calibration Range	100 g – 2 kg
F2 Calibration Range	10 g – 2 kg
M1 Calibration Range	1 g – 2 kg
M2 Calibration Range	1 g – 2 kg
Maximum capacity [Max]	2.3 kg
Readability [d]	0.1 mg
Standard repeatability [5% Max]	0.08 mg
Standard repeatability [Max]	0.1 mg
Permissible repeatability	0.2 mg
Eccentricity (tested load)	0 mg*
Electric compensation range	-50 g – +300 g
Stabilization time	20 s
Adjustment	internal

Physical parameters	
Display	10" graphic colour touchscreen
Weighing pan dimensions	ø70 mm
Weighing device dimensions	385×215×525 mm
Controlling device dimensions	249×170×72 mm
Anti-draft chamber dimensions	660×470×700 mm
Packaging dimensions	945×820×1260 mm
Chamber packaging size	820×850×630 mm
Net weight	39.5 kg
Gross weight	59.5 kg
Supplementary weights internal	automatic
Supplementary weights external	2×100 g

Communication interface	
Communication interface	2×USB-A, USB-C, HDMI, Ethernet, Wi-Fi, Hotspot

Environmental conditions	
Operating temperature	+15 – +30 °C
Operating temperature change rate	±0.5 °C / 12 h (±0.3 °C / 4 h)
Relative humidity	40% – 60%
Relative humidity change rate	±3% / 4 h

Repeatability is expressed as a standard deviation determined for 6 ABBA cycles. Standard deviation is experimentally determined under ambient conditions for calibration of E1 class mass standards specified in OIML R111 (Table C.1.) document.

Eccentricity (tested load) – suspended self-centring weighing pan (available as an option): 0 mg.

* **Eccentricity (tested load):** 1 d / mm.

* Wi-Fi® is a registered trademark of Wi-Fi® Alliance.



Accessories

Suspended Self-Centring Weighing Pan for WAY 5Y.KO Manual Mass Comparator	Label Printers
RFID Tags	THBR 2.0 System - Ambient Conditions Monitoring
Antivibration Tables	Receipt Printer
Additional modules	Fingerprint Reader
Protective cover for balances	RS 232, RS 485 cables
Barcode scanners	RS 232 cables (scale - printer)
RS 232, RS 485 cables	

Software

- RAD Key [WX-010-0005]
- RMCS System Network Management of Calibration Process [WX-010-0048]
- RMCS Lite [WX-010-0164]

Device dimensions



WAY 5.5Y.KO

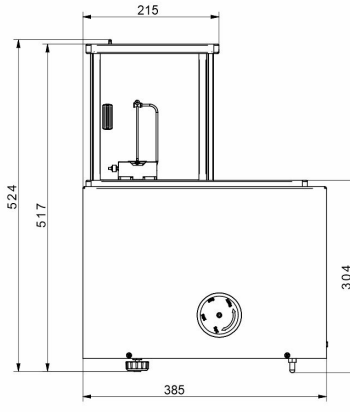

WAY 100.5Y.KO

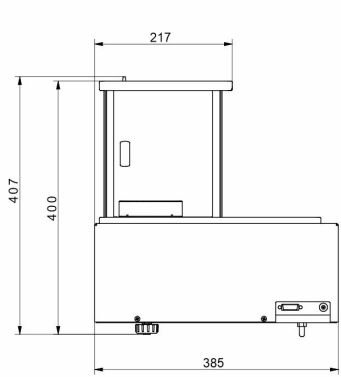
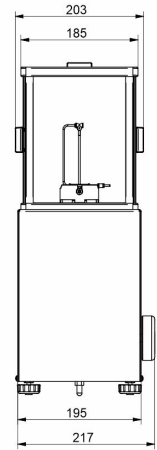

WAY 1200.5Y.KO

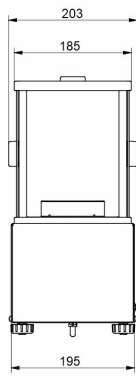

WAY 5100.5Y.KO

