



More information on the website
mirror.radwag.com/en/info,w1,253

MWLH 10 Electromagnetic Compensation Weighing Module



The drawings, photos and graphics used are for illustrative purposes only.

Datasheet

Metrological parameters	
Maximum capacity [Max]	10 kg
Minimum load	0.5 g
Preload range	1 kg
Readability [d]	0.01 g
Tare range	-10 kg
Repeatability	0.01 g
Linearity	±0.02 g
Stabilization time	3 s
Adjustment	external
Construction	
Protection class	IP 65
Electrical parameters	
Power supply	100 – 240 V AC 50/60 Hz

Environmental conditions

Operating temperature +10 – +40 °C

Relative humidity 15% – 80%

Physical parameters

Weighing pan dimensions 212×174 mm

Device dimensions 341×236×164 mm

Packaging dimensions 580×413×360 mm



Accessories

RS 232 cables (scale - Ethernet)

RS 232, RS 485 cables

IN/OUT Cables

Powerbanks

RS 232 – USB Converter

Software

• MWMH Manager [WX-010-0103]

• R-Lab [WX-010-0080]

• RADWAG Development Studio [WX-010-0104]

• RAD Key [WX-010-0005]

• Scale Editor 2.1 [WX-010-0173]

Device dimensions

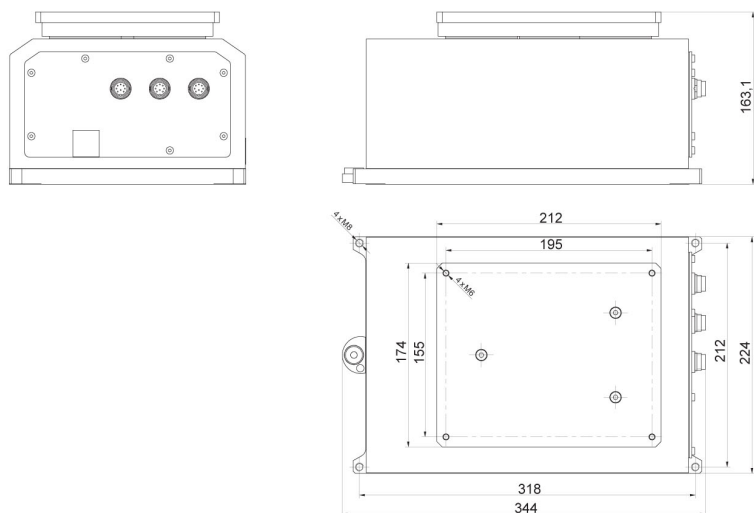

MWLH