



More information on the website
mirror.radwag.com/it/info,w1,1H6

MPS 6000 Modulo di pesatura



The drawings, photos and graphics used are for illustrative purposes only.

Specifiche

Parametri metrologici	
Portata massima [Max]	6000 g
Portata minima [Min]	500 mg
Intervallo di precarico	600 g
Divisione [d]	10 mg
Campo di tara	-6000 g
Ripetibilita	15 mg
Linearità	±30 mg
Tempo di stabilizzazione	1,5 s
Calibrazione	internal (automatic)
Costruzione	
Punteggio IP	IP 32
Struttura	aluminum
Interfaccia di comunicazione	
Interfaccia	2×RS232, 2×IN PRINT / TARA

Parametri elettrici	
Alimentatore	100 – 240 V AC 50/60 Hz
Environmental conditions	
Ambiente di lavoro	+10 – +40 °C
Umidità relativa	40% – 80%
Parametri fisici	
Dimensione piatto	ø115 mm
Device dimensions	293×190×112 mm
Dimensioni del pacco	515×340×295 mm
Peso netto	4,1 kg



Accessori

Tavoli antivibranti
 Tavolo di pesata professionale
 Cavo seriale RS 232, RS 485

RS 232 – USB Converter
 Cavo seriale RS 232 (connessione bilance - Stampanti)

Software

- RAD Key [WX-010-0005]
- R-LAB [WX-010-0080]

- R Panel [WX-010-0187]
- Software „Development Studio“ RADWAG [WX-010-0104]

Device dimensions

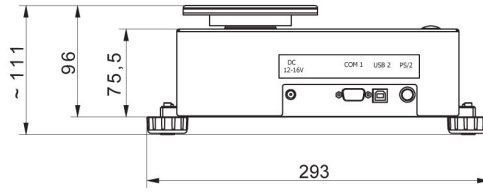
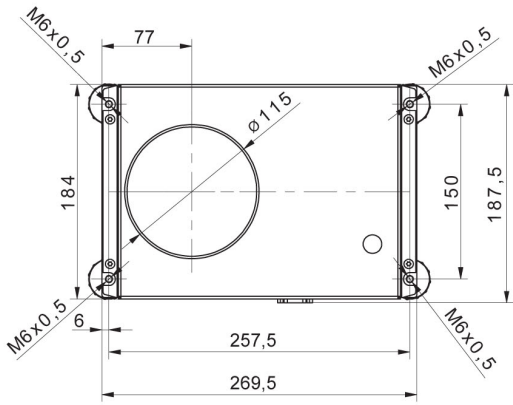

MPS

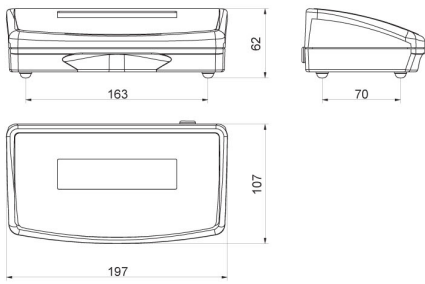

R operator panel

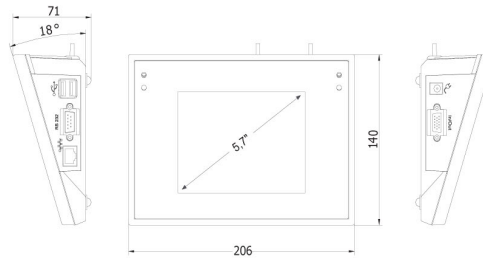

Y operator panel