



More information on the website
mirror.radwag.com/us/info,w1,1EM

SAL/STONE/H Antivibration Table

WX-001-0079



The drawings, photos and graphics used are for illustrative purposes only.

Datasheet

Construction	
Construction	Stainless steel AISI304
Load-bearing capacity	150 kg
Physical parameters	
Packaging dimensions W x D x H	1200×800×970 mm
Net weight	215 kg
Gross weight	255 kg
Length	1000 mm
Width	650 mm
Height	815 mm



Compatible with (Additional Fee)

H315 HR Waterproof Platform Scale
 MA X7.IC.A Moisture Analyzer
 HX7 H Multifunctional Scale
 HX7 HR Multifunctional Scale
 XA 5Y.M.A.P Microbalance for pipettes calibration
 MYA 5Y.P Microbalance for pipettes calibration
 MA 5Y Moisture Analyzer
 Tunnel detectors
 C315 Platform scale
 5Y.PM Precision balance
 MYA 5Y.F Microbalance for Filters
 AS X7 Analytical Balance
 XA 5Y.M.A Microbalance
 WLC Precision Balance
 PS R2 Precision Balance
 WLC X7 Precision balance
 H315 H Waterproof Platform Scale
 HY10 H Stainless Steel Multifunctional Scale
 C32.PM Precision Balance
 Automatic Balances for. Pipettes Calibration
 MA X7.A Moisture Analyzer
 XA 5Y.A Analytical Balance
 WAY 5Y.KO Manual Mass Comparator
 UYA 5Y Ultra-Microbalance
 MA 5Y.IC Moisture Analyzer
 MA R Moisture Analyzer
 AS 5Y Analytical Balance
 AK-4 Automatic Mass Comparator

PS 5Y Precision Balance
 PS 5Y Balances for PGC
 PS R2.H Precision Balance
 WTC Precision Balance
 CY10 Precision balance
 Analytical Balance for Filters XA 5Y.F
 WLY Precision Balance
 UMA Automatic Mass Comparator
 PS X7 Precision Balance
 Density measurement
 WLC C/2 Precision balance
 MYA 5Y Microbalance
 PS R1 Precision Balance
 XA 5Y Analytical Balance
 Manual susceptometers - Magnetization
 AS R2 PLUS Analytical Balance
 PMV 5Y Moisture Analyzer
 Automatic susceptometers - Magnetization
 XA 5Y.KO Manual Mass Comparator
 XA 5Y.M Microbalance
 UYA 5Y.KO Manual Mass Comparator
 AS R1 PLUS Analytical Balance
 UYA 5Y.F Ultra-Microbalance for Filters
 APP 5Y.KO Manual Mass Comparator
 Nano-Comparator NANO.AK-4.500.5Y
 XA 5Y.M.A.S Microbalance for stents weighing
 MAS.1.Y Modules

Device dimensions W x D x H

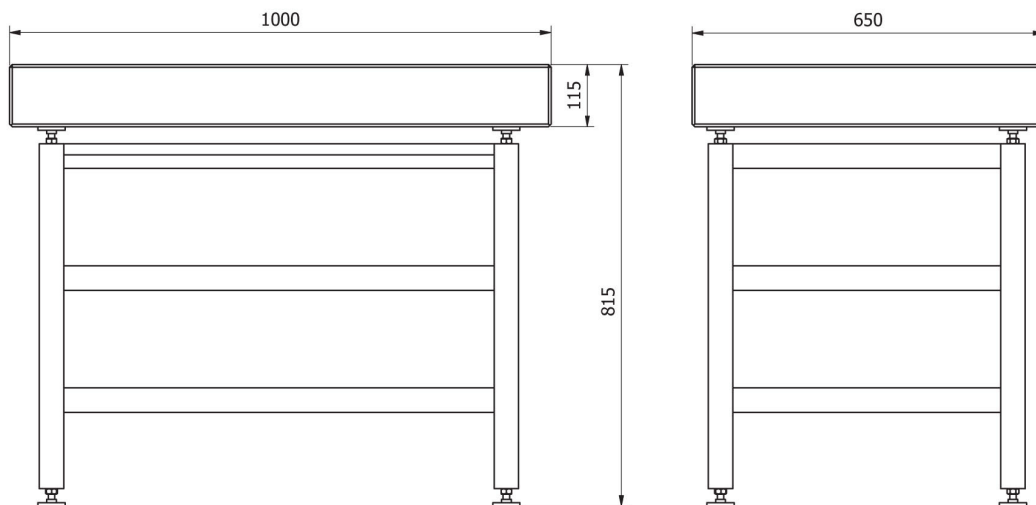

SAL/STONE