



# PS 10100.R2.M Precision Balance

WL-212-0133

More information on the website  
[mirror.radwag.com/us/info,w1,0TW](http://mirror.radwag.com/us/info,w1,0TW)



The drawings, photos and graphics used are for illustrative purposes only.

## Functions

-  Autotest
-  Dosing
-  Percent Weighing
-  Totalizing
-  Parts counting
-  Peak hold
-  Newton unit measurement
-  Statistics
-  Checkweighing
-  Under-pan weighing
-  GLP Procedures
-  Animal weighing
-  Density determination

## Datasheet

Metrological parameters	
Maximum capacity [Max]	10100 g
Minimum load	-
Readability [d]	10 mg
Verification unit [e]	-
Tare range	-10100 g
Minimum weight (USP)	10 g

<b>Metrological parameters</b>	
Minimum weight (U=1%, k=2)	1 g
Standard repeatability [Max]	12 mg
Standard repeatability [5% Max]	5 mg
Linearity	±20 mg
Stabilization time	1,5 s
Adjustment	internal (automatic)
OIML Class	-
Sensitivity temperature drift	$2 \times 10^{-6} / ^\circ\text{C} \times \text{Rt}$
<b>Physical parameters</b>	
Leveling system	manual
Display	5,3" LCD (backlit)
Delivery components	Balance, weighing pan, weighing pan shield, power supply
Weighing pan dimensions	195x195 mm
Device dimensions W x D x H	333x206x107 mm
Packaging dimensions W x D x H	475x380x345 mm
Net weight	4,33 kg
Gross weight	5,5 kg
<b>Construction</b>	
Protection class	IP 43
<b>Communication interface</b>	
Communication interface	2xRS232 <sup>1</sup> , USB-A, USB-B, Wi-Fi (option)
<b>Electrical parameters</b>	
Power supply	Adapter: 100 – 240V AC 50/60Hz 0.6A Max; 12V DC 1,2A Balance: 12 – 15V DC 0,7A max; 3 – 5,5W*
Power consumption	4 W
<b>Environmental conditions</b>	
Operating temperature	+10 – +40 °C
Storage temperature	-20 – +50 °C
Relative humidity	40% – 80%

\* Wi-Fi® is a registered trademark of Wi-Fi® Alliance.



## Accessories (Additional Fee)

!Balance Storage Case  
 Antivibration tables  
 Power Adapters  
 Cigarette lighter receptacle power supply cables  
 USB cable (scale - printer)  
 Barcode scanners  
 RS 232, RS 485 cables

Displays  
 Density determination KIT  
 Protective cover for balances  
 Receipt Printer  
 Under-pan weighing  
 RS 232 cables (scale - printer)

## Software (Additional Fee)

- RAD Key [WX-010-0005]
- Alibi Reader PC Software [WX-010-0114]

- R Panel [WX-010-0187]
- RADWAG Development Studio [WX-010-0104]

## Device dimensions W x D x H

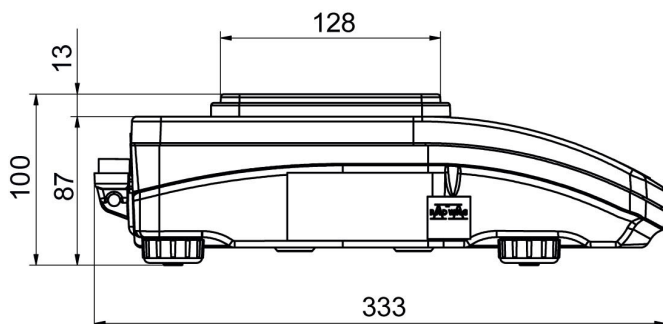

PS R, d = 1 mg

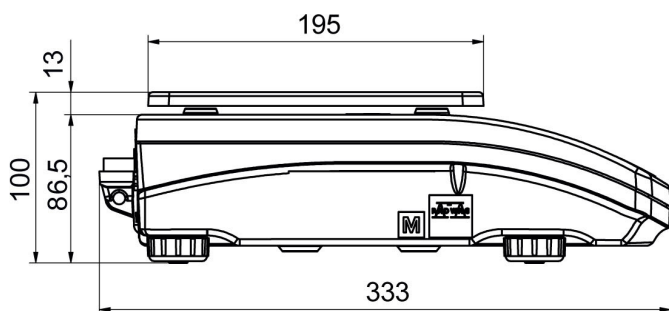
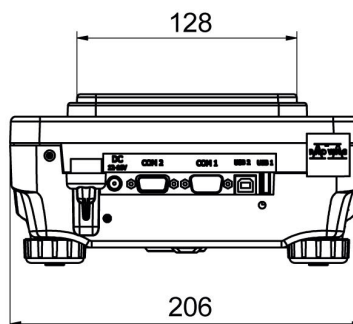

PS R, d = 10 mg

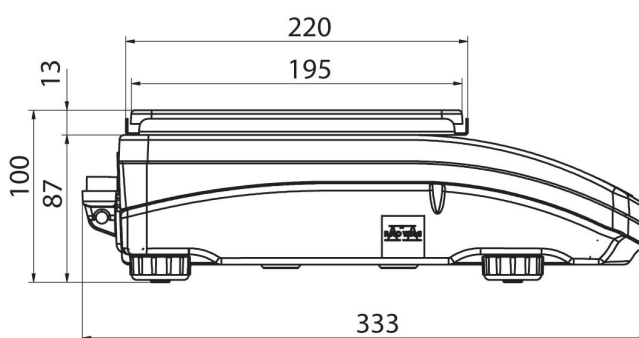
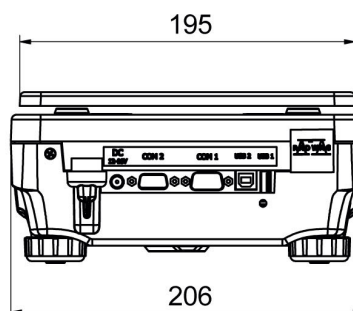

PS R.M, d = 10 mg

