



More information on the website
mirror.radwag.com/it/info,w1,02A

MAS.1.51.Y Modulo di pesatura



The drawings, photos and graphics used are for illustrative purposes only.

Specifiche

Parametri metrologici	
Portata massima [Max]	51 g
Portata minima [Min]	1 mg
Intervallo di precarico	5,1 g
Divisione [d]	0,01 mg
Campo di tara	-51 g
Portata minima (secondo USP)	24 mg
Portata minima (U=1%,k=2)	2,4 mg
Ripetibilita (Max)	0,025 mg
Ripetibilita (5% Max)	0,012 mg
Linearità	±0,06 mg
Tempo di stabilizzazione	6 s
Parametri fisici	
Display	LCD (backlit)
Dimensione piatto	ø33 mm
Device dimensions	289×143×125 mm

Parametri fisici	
Dimensioni del pacco	650×340×315 mm
Peso netto	4,7 kg
Peso lordo	6,7 kg
Costruzione	
Punteggio IP	IP 54
Interfaccia di comunicazione	
Interfaccia	RS232
Parametri elettrici	
Alimentatore	100 – 240 V AC 50/60 Hz
Environmental conditions	
Ambiente di lavoro	+10 – +40 °C
Umidità relativa	40% – 80%



Accessori

Cavo seriale RS 232 (connessione bilance - Stampanti)
 Tavoli antivibranti
 Cavo seriale RS 232, RS 485

Tavolo di pesata professionale
 RS 232 – USB Converter
 Cavo seriale RS 232, RS 485

Software

- RAD Key [WX-010-0005]
- R-LAB [WX-010-0080]

- R Panel [WX-010-0187]
- Software „Development Studio“ RADWAG [WX-010-0104]

Device dimensions



MAS.1
MAS.1.R



MAS.1



MAS.1.Y

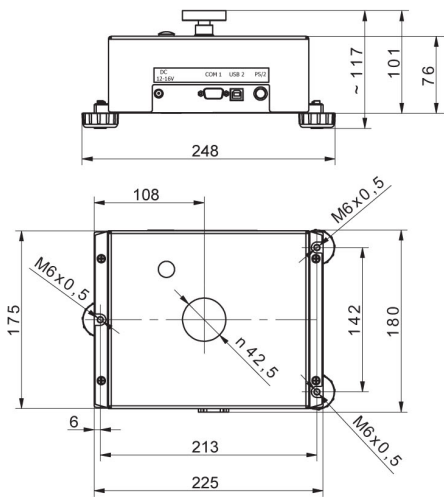

MAS



R operator panel

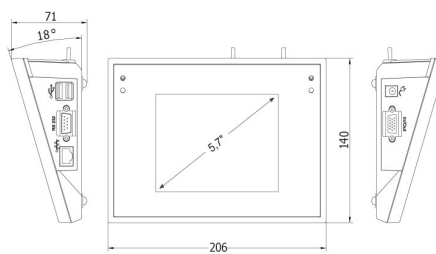

Y operator panel